

Skyline Installation

1. MOUNT THE BRACKETS.

Attach the brackets to the window frame, window molding, wall or ceiling, as shown.

Brackets are universal so clutch may be mounted on either side.

Note: If sharing a standard bracket between two shades, bracket can only be shared by a clutch and a pin end, not clutch-to-clutch or pin end-to-pin end. If sharing an intermediate bracket it can only be shared by two pin ends

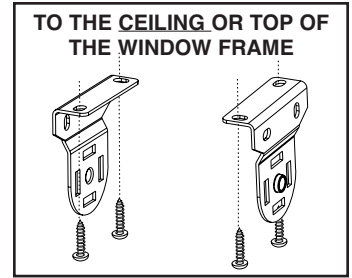
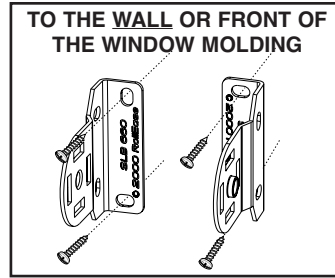
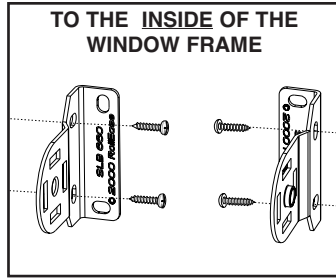

2. INSTALL THE SHADE

- a. Put the spring loaded pin end into the round hole of the bracket.
- b. Keeping the pin end secured in its bracket, insert the hooks on the clutch straight into the two slots in the bracket. Once the two hooks are through the slots, gently pull down on the clutch until the two hooks have locked securely to the bracket. The bottom of the clutch should point straight down.

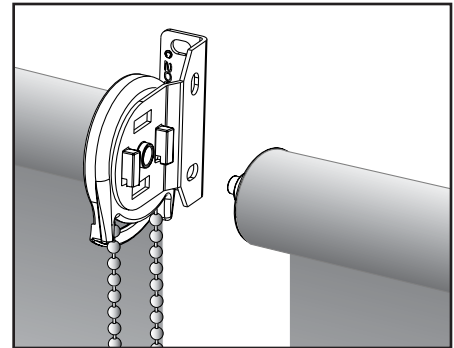
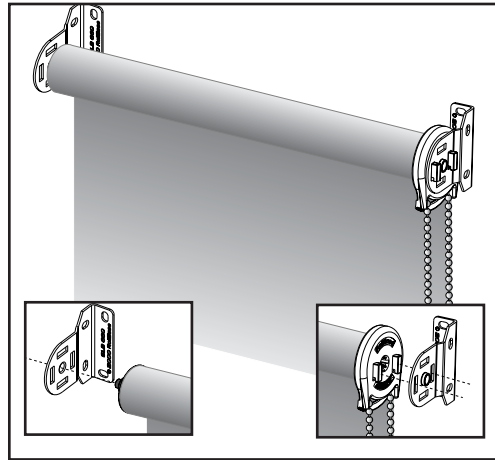

Note: If sharing a bracket between two shades, bracket can only be shared by a clutch and a pin end, not a clutch-to-clutch or pin end to pin end.

3. INSTALL THE BRACKET COVERS

Bracket covers slide over the bracket until snapped into position.

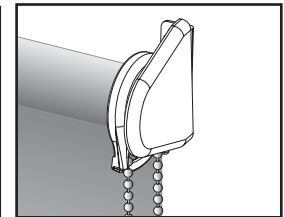
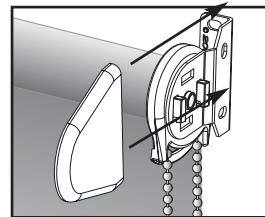

4. INSTALL THE TENSION DEVICE

See details page SL22



5. USE THE CONTROL CORD OR BEAD CHAIN TO OPERATE THE SHADE.

Pulling gently on the cord in one direction raises the shade; pulling it in the other direction lowers it.

6. ATTACH STOPS TO A CONTROL CORD THAT'S MADE OF BEAD CHAIN.

On metal bead chain, attach a metal stop ball that is at least 5/16" (8mm) in diameter, so that it touches the clutch when the shade is in the fully raised position.

For metal or plastic bead chain, lower the shade to its fully lowered position, and attach the appropriate metal stop or plastic connector next so that it touches the clutch, this prevents the shade from being lowered beyond that point.