

## BASICS

A few simple tools are required:

- Measuring tape
- Power drill, drill bits
- Hex head and/or Phillips driver bit
- Pencil

Additional fasteners other than those sent with your shade may be required depending on the mounting surface. Wallboard and plaster require the use of anchors such as expansion or toggle bolts. Brick, tile or stone need special plugs and drill bits. Remember to always pre-drill holes in wood to avoid splitting.

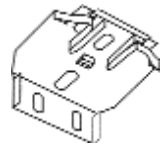

Standard and Top-Down Bottom Up Installation Bracket

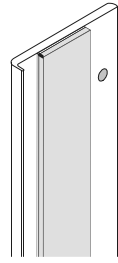

Shallow Mount Adapter with Magnet

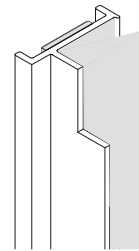

Side Track Rail with Magnet

The minimum required depth for shallow mount installation is 1/2".

## BRACKET INSTALLATION

Shades are shipped with the required number of brackets for proper installation. End brackets should be located with centerlines 3-1/2" in from each end. Depending on the width of the shade, additional brackets may be necessary evenly spaced between the two end brackets.

For shade widths of:	Use this Number of brackets:
Up to 40"	2
40" - 72"	3
72" - 84"	4
84" and up	5

The brackets are mounted flat against the top sill surface.

The minimum depth required is 1/2".

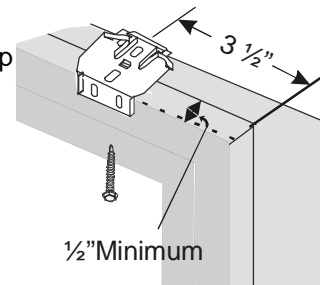

## SHALLOW MOUNT ADAPTER INSTALLATION

Align the back of the adapter with the back of the installation bracket.

Mark the hole positions. Pre-drill the holes to avoid splitting.

Attach the adapter with the screws provided.

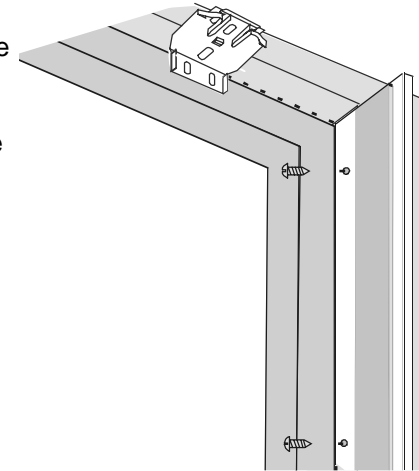

## SHADE INSTALLATION

Unwind the cord from the shade. Bring the top rail up near the installation brackets. Center the shade in the window opening and attach the headrail to the installation brackets.

Insert the front clip of the installation bracket into the front groove of the rail.

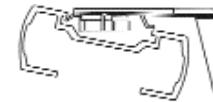

Push the rail back and up until the back clips of the bracket are inserted in the back groove of the rail.



Carefully slide the top of the track into the notch in the shade, making sure that the Z seal is toward the back and push up.

Let the track snap onto the magnet. Repeat for the other side.

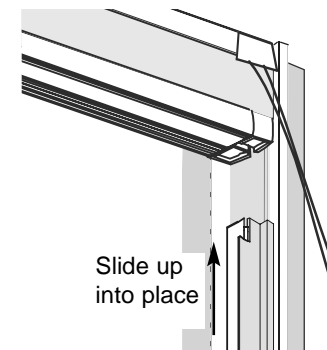

## OPERATION

### Standard Shades

To lower or release shade, pull the cord inward toward the center of the shade. To raise or lock the shade, pull the cord straight down and outward toward the edge of the shade.

### Top-Down Bottom Up

One cord will raise or lower the bottom rail, the other cord will raise or lower the top. Pull the cord inward toward the center of the shade to lower or release shade. Pull the cord straight down and outward toward the edge of the shade to raise or lock the shade.

## BREAKTHROUGH CORD CONNECTOR

The breakthrough cord connector applies to Standard and Top-Down Bottom-Up shades.



### WARNING

To avoid entanglement and strangulation, keep cords out of the reach of young children. Move cribs and furniture away from blind cords.

To further reduce hazards, this shade was built with a cord connector which was designed to break apart when force is applied from the top.

**No safety system is fail-safe. KEEP CORDS OUT OF REACH OF SMALL CHILDREN!**

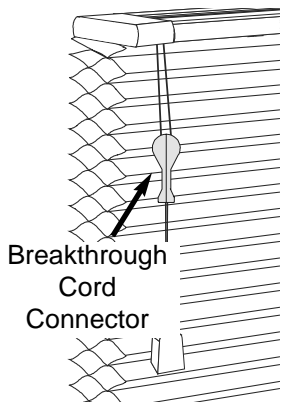

If your cord connector should happen to break apart, follow the instructions below to reassemble.

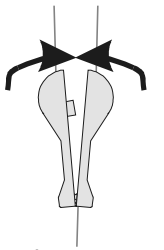
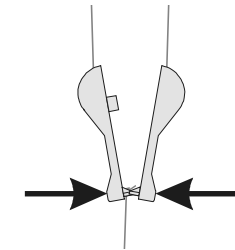
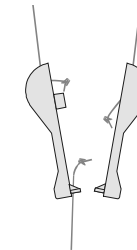

When the connector is open, each side has a cord coming in at the top, one side has a cord coming in from the bottom. Fit the bottom edges together. The side with the cord fits into the side without the cord. Swing the top ends together and press in the middle to fully connect.

## PROTECT YOUR CHILDREN

Be aware that it is possible for children to strangle in window covering cords. To reduce the occurrence of accident, all cords must be kept out of the reach of children, including infants. Cord cleats and Tensioner devices are an effective way to implement this essential precaution.

### Standard and Top-Down Bottom-Up

Mount the cord cleat at a safe height, taking into account furniture or other objects upon which a child may climb. Then, after each use of the shade, simply wrap the excess cord around the cleat. It's fast, easy and safe.

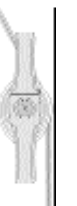

## **EQUALIZATION**

If the shade length and equalization is satisfactory, simply trim the excess cord hanging below the bottom rail.

If adjustments are necessary, pull the excess cord at the bottom of the shade down until the Bottom Rail Plug is released (fig. A). Push the cord up or down through the Bottom Rail Plug (figs. B & C).

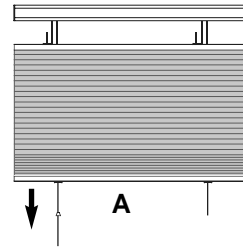

If the cord needs to be longer, slide the bottom end of the cord up into the wedge and slide the wedge down to take up slack.

If the cord needs to be shorter, slide the top end of the cord down into the wedge and slide the wedge up to take up slack.

Adjust the position of the plug as necessary (fig. D).

Feed the cord back through the Bottom Rail Plug (figs. E & F).

Push the Bottom Rail Plug back into the Bottom Rail Pocket.

When bottom rail adjustments have been made, trim the excess cord hanging below the bottom rail.

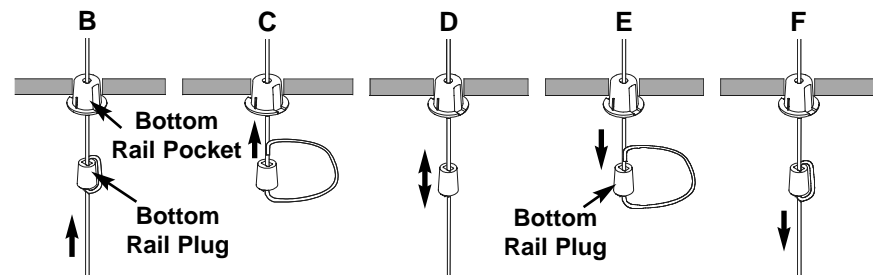

## **TROUBLE SHOOTING**

*Problem:* Shade is difficult to operate, especially near the top.

*Cause:* Brackets and Side Track may not be properly aligned.

*Repair:* Adjust brackets as necessary so the track is centered in the bottom rail end cap.

## **CLEANING AND CARE**

The Shade fabric is easy to care for. Regular dusting with a feather duster or vacuum cleaner brush is recommended. Most stains can be blotted with a damp sponge and mild detergent. For problem stains, the shade can be removed from the Installation brackets and soaked in warm water. When damp, raise shade tightly to re-crisp pleats.

## **ENERGY EFFICIENCY**

Your Comfortex shade with Comfortrack is designed to block the loss of heat through your windows while preserving the opportunity to enjoy the "free" energy available from direct sunlight.

For maximum energy savings in most windows, the shade should be fully lowered to enhance insulation during non-daylight hours.

In sunlight windows, a net solar energy gain may be achieved during the heating season by opening the shade during bright daylight hours to admit energy from sunlight into the interior room space.

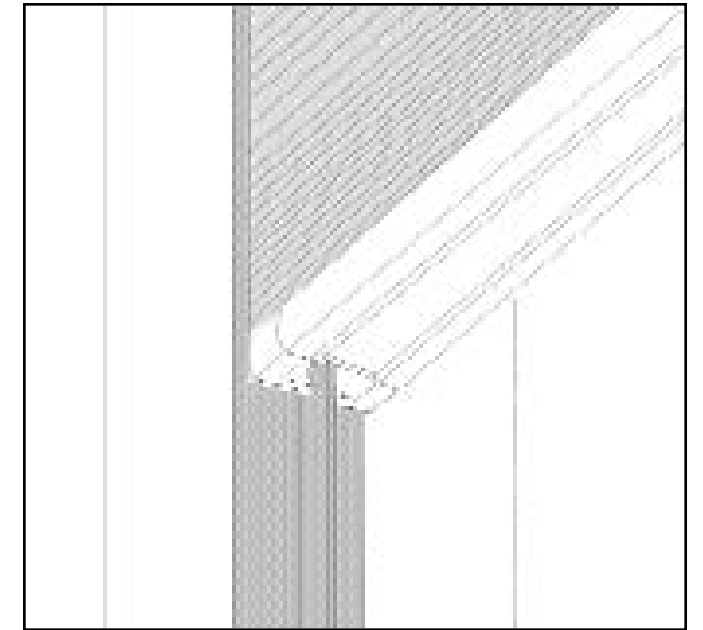

## **Side Track**

Energy Saving Shade System

## **Shallow Mount Application**

### Installation Instructions

Our window fashions represent a design breakthrough in style, efficiency and function. Our Cellular shades feature 100% non-woven polyester fabric providing a soft diffused light and high level of privacy. The unique hardware system is designed to provide years of reliable service when properly installed.

Please take a few minutes to read through these instructions before beginning.